

Reg. No.

--	--	--	--	--	--	--	--	--	--	--	--	--	--	--	--	--	--	--	--

MECH - III

**Question Paper Code : 27270**

**B.E./B.Tech. DEGREE EXAMINATIONS, NOVEMBER/DECEMBER 2015**

**First Semester**

**Mechanical Engineering**

**GE 6152 : ENGINEERING GRAPHICS**

**(Common to all Branches)**

**(Regulations : 2013)**

**Time : Three Hours**

**Maximum : 100 Marks**

**Note :** Blank Answer Booklet consisting of A3 drawing sheets is to be supplied to the students.

**Answer ALL questions. (5 × 20 = 100 Marks)**

1. (a) Draw a hyperbola given the distance of the focus from the directrix as 55 mm and eccentricity as 1.5. Also draw a tangent and normal at any point P on the hyperbola.

**OR**

- (b) Sketch freehand the top, front and right side views of the object shown in Figure.

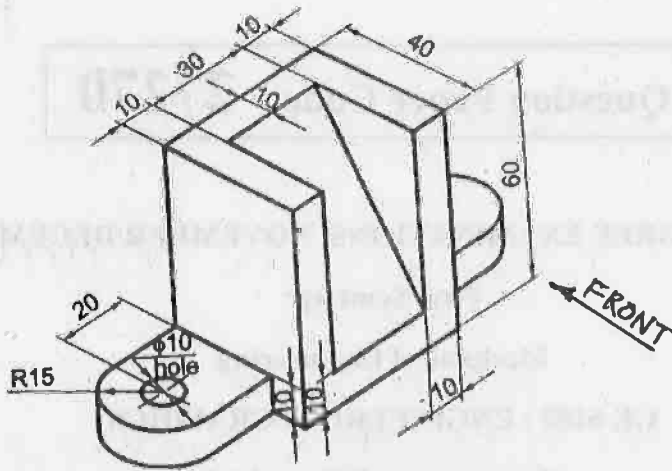

NOTE : ALL DIMENSIONS ARE IN 'mm'

2. (a) A line NS, 80 mm long has its end N, 10 mm above the HP and 15 mm in front of the VP. The other end S is 65 mm above the HP and 50 mm in front of the VP. Draw the projections of the line and find its true inclinations with the HP and VP.

OR

- (b) A rectangular plate measuring  $55 \times 30$  mm is resting on its shorter side on the HP inclined at  $30^\circ$  to the VP. Its surface is inclined at  $60^\circ$  to the HP. Draw its projections.

3. (a) A hexagonal prism of base side 30 mm and axis length 60 mm rests on the HP on one of its base edges with its axis inclined at  $60^\circ$  to the HP and parallel to the VP. Draw its top and front views.

OR

- (b) Draw the projections of a cube of side 40 mm when it rests on one of its corners with a diagonal of the solid vertical.

4. (a) A square pyramid of base side 25 mm and altitude 40 mm rests on the HP on its base with the base edges equally inclined to the VP. It is cut by a plane perpendicular to the VP and inclined at  $30^\circ$  to the HP meeting the axis at 21 mm above the HP. Draw the sectional top view and the true shape of the section.

**OR**

- (b) A pentagonal pyramid of base side 25 mm and altitude 50 mm rests on its base on the HP with one of the sides of the base parallel to the VP. It is cut by a plane bisecting the axis. The cutting plane is inclined at  $30^\circ$  to the base and perpendicular to the VP. Draw the development of the lateral surfaces of the lower part of the cut pyramid.

5. (a) A cylinder of base diameter 30 mm and axis 50 mm is placed on its base centrally on the top of a square slab of side 50 mm and thickness 20 mm. Draw the isometric projection of the combination of solids to full scale.

**OR**

- (b) A regular hexagonal pyramid of base edge 20 mm and height 35 mm rests on its base on the ground plane with one of its base edges touching the picture plane. The station point is 30 mm above the ground plane and 40 mm in front of the PP. The central plane is 30 mm to the right of the axis. Draw the perspective projection of the pyramid by visual ray method. Use the top view and the front view.